

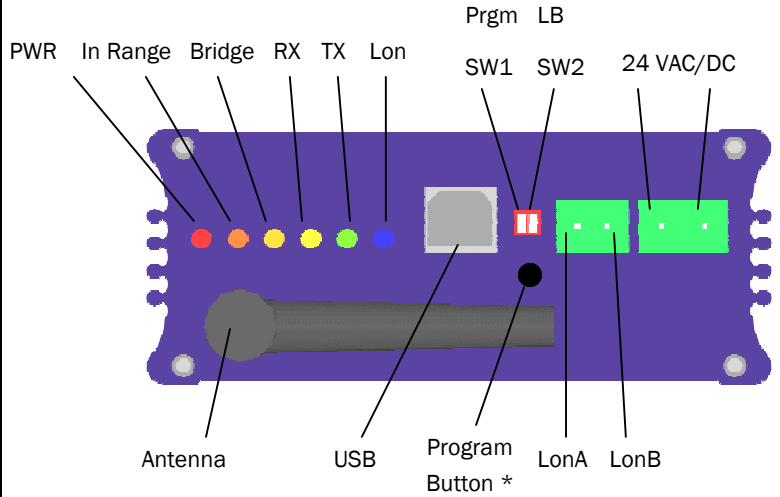

WLD242

The WLD242 is a device designed to transport LonWorks® communication data over short to extended ranges using the 2.4 GHz frequency. The WLD242 is designed to be plug-and-play, requiring no special programming tools. Using a simple software tool (provided) radios can be addressed to one another in the field. The WLD242 has an embedded 200 mW radio. See below for installation instructions and configuration.

Antenna	RPSMA Connector (not to exceed 6 dB gain)
Power	Power LED
In Range	Solid state on client = in range of server
Bridge	Bridge LED, indicating LonWorks Conversion
TX	Transmit indicator
RX	Receive indicator
Lon	LonWorks communication indicator
USB	USB program port
Prgm	Program mode
LB	Loop back mode
LonA	LonWorks data connection A (non polarity)
LonB	LonWorks data connection B (non polarity)
PWR	24VAC/DC (non polarity sensitive) * see Warning
GND	24VAC/DC (non polarity sensitive) * see Warning



Operating Voltage: 12-24 VAC/DC

Power Consumption at Max Power: 1.2A @ 12VAC/DC

*** WARNING: If using AC power option, 24 VAC isolation transformer must be used! Ensure neither of the two secondaries are bonded.**

*** Program Button must be depressed and held while programming the radio.**

INSTALLATION INSTRUCTIONS:

1. Connect Lon bus as labeled in the above diagram.
2. Connect 24 VAC/DC power as labeled in the above diagram.
3. Red power Led should light up.
4. Adjust dip switch for desired operation.
5. Perform a *local commission* on the remote Lon installation.
6. Verify the Rf network communication with the In Range, TX, RX, and Lon led indicators. These led lights will flash on and off only with the presence of LonWorks communication when in the normal operating mode.
7. Lastly, perform a commission at the base station site to establish the link with the remote location.

Note: As with any Rf network, plan ahead for antenna location and placement. It is the intention of AIC Wireless to provide a reliable wireless communication device for existing LonWorks networks. However, in some conditions, reliability is determined largely by correct antenna placement, which is the responsibility of the installer. Using good judgment in antenna placement will help decrease service related issues and increase reliability. This product is NOT TO BE USED in situations where life safety issues may arise. AIC Wireless makes no claims, expressed or implied, of the products usefulness with regard to specific applications. Determination of the product's suitability for an application is the sole responsibility of the purchasing parties. In any installation application, ensure devices are properly protected from the elements by installing in appropriate enclosure. Additional surge protection devices may be necessary to protect from lightning/power surges.

Dip Switch Instructions: (note: on is in the up position, towards the label)

1. SW1 On/SW2 On Radio Program Mode
2. SW1 Off/SW2 On Normal Operating Mode
3. SW1 Off/SW2 Off No Function (*do not use*)
4. SW1 On/SW2 Off Loop Back Test Mode (*used for range testing*)

Possible Network Illustrations:

Point-to-point



One to One Addressing

Point-to-multipoint

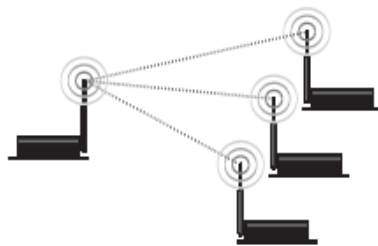

One to Many Addressing

Broadcast Mode

(Not a mesh network)

For Support Information, contact AIC Wireless at 229-776-2510, or e-mail support@aic-wireless.com.
For Sales Information, contact AIC Wireless at 229-776-2510, or e-mail sales@aic-wireless.com.

FCC ID: KQL-PKLR2400-200

IC: CAN2268391180A

This device complies with Part 15 of the FCC rules. Operation is subject to the following two conditions: (1) This device may not cause harmful interference: (2) This device must accept any interference received, including interference that may cause undesired operation.